



RMS Building,
Heapham Road Ind Est
Gainsborough,
Lincolnshire,
DN21 1RZ

Tel/Fax: 01427 811095
Mobile: 07918731908 / 9
email: sales@liftsafesolutions.co.uk

VERTICAL LIFTING CLAMP (Stopper type)



SVC 0.5 ~ 5

Clamp for the vertical lifting of steel plates and steel structures (Compact lightweight design)

FEATURES

- All of the major components are within the body, and there is no projection from the body for easy operation.
- When the stopper mechanism is set, the cam will be locked in an open position, and will be easy to set the clamp onto the work piece. The work piece cannot be lifted while the clamp is unlocked, and it will be possible to visually confirm that the clamp is unlocked.
- The clamping force increases in proportion to the weight of the load.
- The main body and the shackle are made of die-forged special alloy steels, which are optimally tempered for maximum strength and durability.
- High-frequency quenching of die-forged special alloy steels gives greater durability to the cam.
- The main body is a baked-on finish.

SPECIFICATIONS

Item No.	Rated capacity (ton)	Jaw opening (mm)	Net weight (kg)	Remarks
SVC 0.5	0.5	0~19	1.5	
SVC 1	1	0~25	3	
SVC 2	2	0~32	6	
SVC 3	3	0~38	9	
SVC 5	5	0~50	18	

CLAMPING & SETTING THE STOPPER MECHANISM

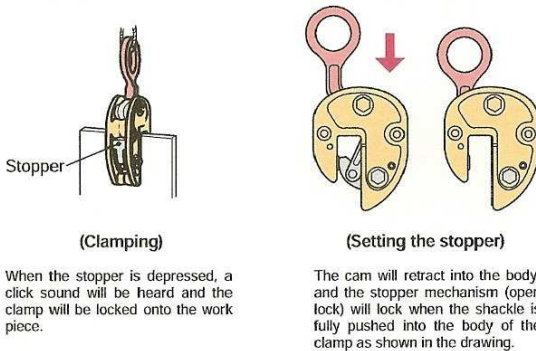

EXAMPLES OF USE

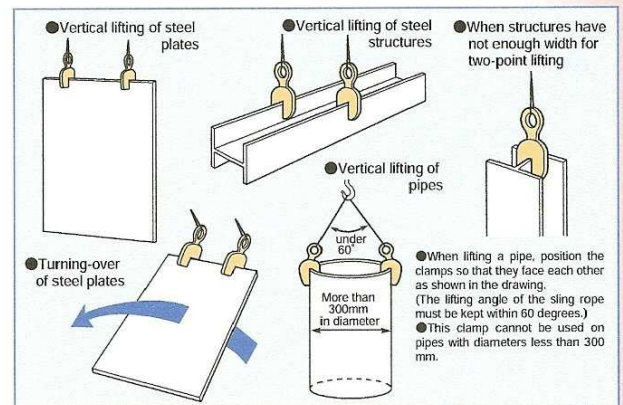

⚠ Always lift work pieces at 2 or more points for safety.

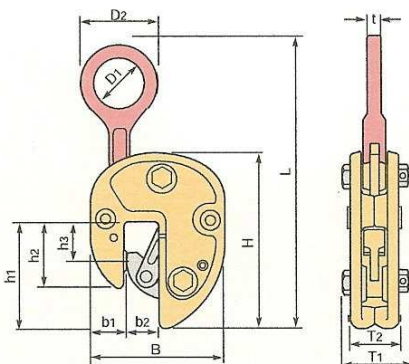

DIMENSIONS TABLE

(Unit:mm)

Item No.	L (MAX)	H	h ₁	h ₂	h ₃	B	b ₁	b ₂	D ₁	D ₂	T ₁	T ₂	t
SVC 0.5	210	138	85	54	33	108	29	22	35	54	45	31	9
SVC 1	265	165	101	62	38	126	35	28	46	72	58	42	12
SVC 2	330	200	120	73	45	152	43	35	61	96	72	56	16
SVC 3	385	225	135	81	48	168	47	41	74	116	84	66	19
SVC 5	485	276	162	99	61	212	59	54	92	146	101	81	25